

Brake Proportioning Valve

HOW IT WORKS

Tilton Engineering's patented, adjustable hydraulic brake proportioning valve enables the driver, or a crew member, to adjust the brake-force to a particular wheel (or wheels). The light, rugged valve may be bulkhead or panel-mounted. The proportioning valve can also be used effectively with dual master cylinder systems.

The proportioning valve is often one of the less understood devices bolted onto a racecar. Understanding how it works from a functional standpoint will allow the driver and crew chief to take advantage of its properties for a better racecar setup.

At lower pressures, the Tilton proportioning valve acts as a simple hydraulic connector.

The pressure going into the proportioning valve is equal to the pressure going out. There is a 1:1 ratio between inlet and outlet pressure. The 45° line shown in **Chart 1** and **Chart 2** indicates this pressure range. Once a certain pressure limit is reached, a further increase in line pressure occurs at a reduced rate of 3:1 from inlet to outlet.

The adjustment control alters the point at which the inlet/outlet pressure ratio changes from 1:1 to 3:1. For example, look at the proportioning valve Midpoint Position of **Chart 1** for Screw-type proportioning valves and Position 4 of **Chart 2** for Lever-type proportioning valves. When the master cylinder line (inlet) pressure is above 650 PSI, the caliper line (outlet) pressure is below the pressure in the master cylinder line. The sloping line off to the right (shown in **Chart 1 & 2**) demonstrates this. Below 650 PSI they are equal.

The dual-slope line gives the proportioning valve one advantage over the balance bar system. It can be tuned for a better front-to-rear brake balance under both light and heavy braking. A particular setting of the balance bar gives you a set front-to-rear brake balance, such as 70/30 (70% front/30% rear). Under both light and heavy braking, this balance remains the same. However, the loading on the front and rear axles does not remain the same under different braking conditions. During heavy braking, there is a large load transfer from the rear to the front axle. As the load increases on the front axle you want a higher percentage of the braking force on the front axle. The bend in the graph for the proportioning valve allows this to happen when the proportioning valve is placed in the line for the rear calipers. During heavier braking, a higher percentage of the braking force is distributed to the front calipers.

INSTALLATION NOTES

There are a few items to remember concerning the proportioning valve:

- **Standard Proportioning Valves (P/N 90-1000 & 90-2000)**
AN-3 port with 3/8"-24 threads. Fittings (supplied): AN-3 male to AN-3 male (P/N 73-820); AN-3 male to 3/16" inverted flare (P/N TE2089-188).
- **Metric Proportioning Valve (P/N 90-1003 & 90-2003)**
Threads: M10 x 1.0-6H with 74° included angle at base. No fittings supplied.
- **Lever-type portioning valves:**
A typical setup has the valve oriented in such a way that when the handle is pushed towards the front of the vehicle it reduces the rear brake pressure. When the handle is moved toward the rear of the vehicle it increases the rear brake pressure. Handle can be re-oriented by loosening the jam nut and rotating the handle. To determine which direction to move the handle, refer to Chart 2 and Diagram 4.
- **Screw-type portioning valves:**
Rotating the adjustment knob in a clockwise direction will allow more brake pressure to be applied to the rear brakes, counter-clockwise will reduce the pressure (when installed on the rear calipers line).

Chart 1 (Screw Type)

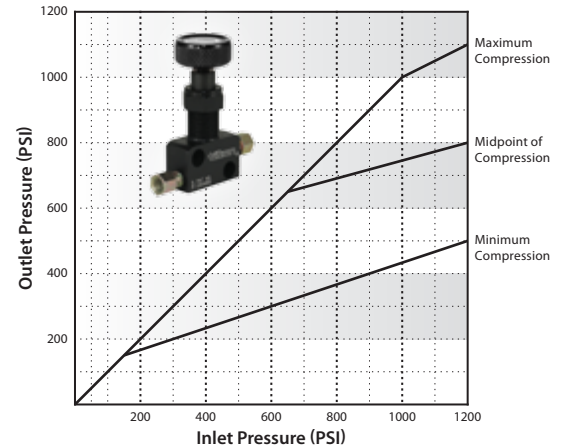
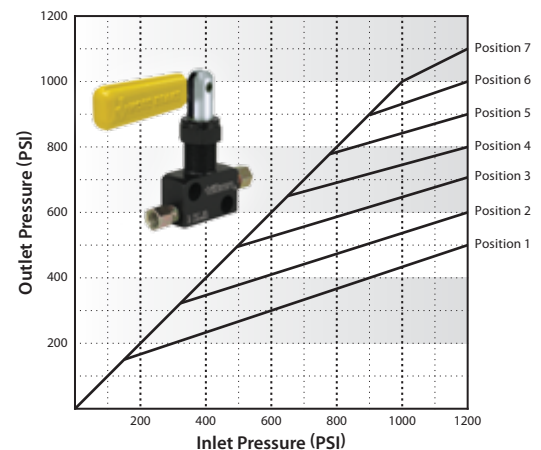

Chart 2 (Lever Type)



- At higher pressures, a piston separates the fluid at the inlet and outlet sides. No fluid flows through the valve. Therefore, you cannot bleed the system at high pressure. Use light pedal pressure, and as an extra precaution, move the lever to Position 7 (lever-type), or rotate adjusting knob in a clockwise direction (screw-type), to reduce internal pressure.
- The proportioning valve can be used to reduce brake line pressure, but will not increase it.
- Hooking it up backwards will not work.
- It can be used very effectively with a balance bar. Set the lever to Position 7 (lever-type) or set adjustment knob to the fully clockwise position (screw-type). Adjust the balance bar until the rear brakes lock on the track with slightly less pedal effort than the front brakes. The proportioning valve is connected to the rear brakes in this case. Then, adjust the valve one position at a time (lever-type) or rotate the knob counter-clockwise (screw-type) until the proper balance is achieved.
- The proportioning valve is ideal for cars that must retain the stock calipers and master cylinder, yet have too much rear brake when running soft tires. A prime example is SCCA A Sedan (AS).

INSTALLATION

Select either the frame or bulkhead mounting style and follow the steps below:

FRAME MOUNTING

1. Select a location for frame mounting the proportioning valve that allows easy access to the adjusting handle/knob.
2. Make sure that the location allows room for the hydraulic lines and access for servicing.
3. Locate and mark the location of the mounting holes on the frame referring to Diagram 4.
4. Drill two 9/32" (7mm) diameter holes in the marked locations. Debur both of the drilled holes.
5. Test fit the valve in the prepared location and select the proper mounting hardware. Use two 1/4" (6mm) diameter socket head cap screws with locknuts. The length will be determined by your application.
6. Select the routing of the hydraulic lines carefully and avoid any heat sources such as the exhaust pipes and manifolds.
7. Refer to Diagram 2 and connect the outlet of the master cylinder to the inlet of the proportioning valve. The outlet of the proportioning valve is connected to the line leading to the caliper(s).

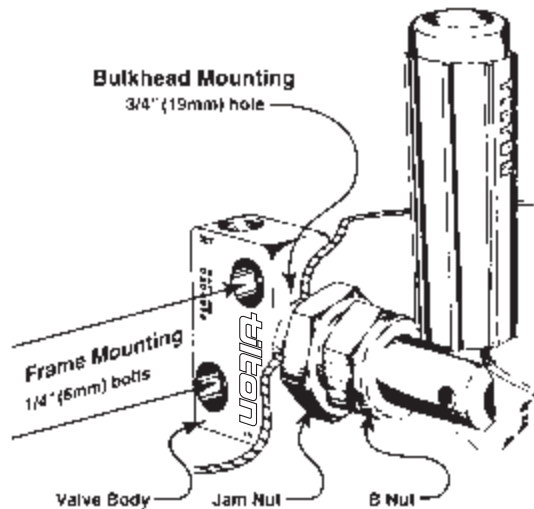

Diagram 1 - Mounting Diagram

BULKHEAD MOUNTING

1. Select the location for bulkhead mounting the proportioning valve that allows easy access to the adjusting handle (knob).
2. Make sure that the location allows room for the hydraulic lines and access for servicing.
3. Locate and mark the location of the mounting hole on the frame referring to Diagram 1.
4. Cut, drill or punch a 3/4" (19mm) diameter hole in the marked location. Debur the hole.
5. Refer to Diagram 1 and loosen the B-nut on the valve body and carefully remove the handle assembly (adjusting knob) from the valve body.
6. Refer to Diagram 1 and loosen and remove the jam nut.
7. Test fit the valve in the prepared location by sliding the valve body through the hole in the bulkhead.
8. Secure the jam nut and insert the handle assembly (adjusting knob) into the valve body.
9. Rotate the handle assembly into the desired position (Lever-type). Tighten top nut (B-Nut) with a 7/8" wrench to 20 ft-lbs before running, and verify the location is suitable for ease of adjustment and servicing. Make sure that the B-nut does not touch the jam nut. Otherwise, the valve handle may not be held in its proper position in the valve body.
10. Select the routing of the hydraulic lines carefully and avoid any heat sources such as the exhaust pipes and manifolds.
11. Refer to Diagram 2 and connect the outlet of the master cylinder to the inlet of the proportioning valve. The outlet of the proportioning valve is connected to the line leading to the caliper(s).

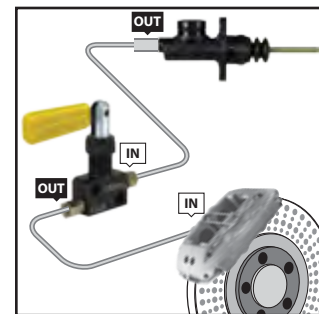

Diagram 2 - Flow Diagram

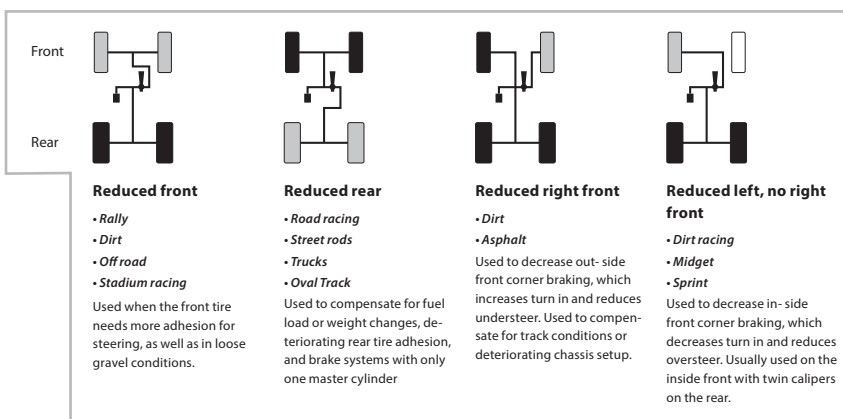

Diagram 3 - Typical Applications

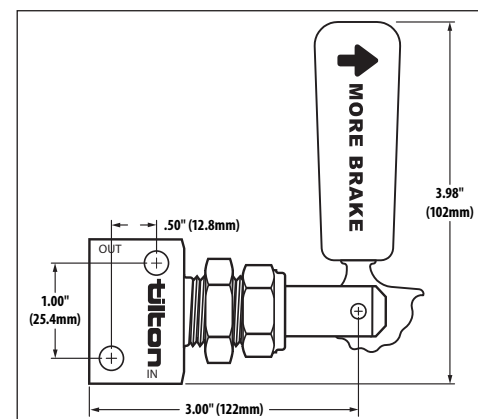

Diagram 4 - Overall Dimensions
(Handle shown in Position 1, referring to Chart 1)